

Vienna Whitsun Social Evening 2024

1 MISS ALLIE ANDERSON J32 · 3/4L

Mina Corson: *The Leaflet Dances with Music* · Crib: *E-cribs* · Diagram: *Keith Rose's Diagrams*

- 1- All clap, 1W+2W+3W dance Rsh once round P to face down with him RHJ ; All lead down the middle
- 9- All M turn P under R arm and lead up to (1x,2x,3x) ; All set, ½ RH turn into
- 17- 1c+2c+3c Promenade (1,2,3)
- 25- 1c+2W RHA, 1M finishing 2pl own side (2M up on [3-4]) ; 1c+2M LHA (2W up on [7-8]) to (2,1,3)

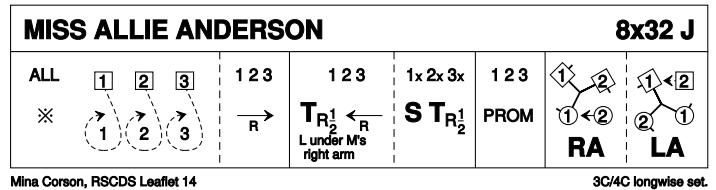

2 THE OLD MAN OF STORR R32 · 3/4L

Roy Goldring: *Scottish Country Dances for Children* · Crib: *E-cribs* · Diagram: *Keith Rose's Diagrams*

- 1- 1c+2c RHA, 1W ends facing out ; 1W (1M following) casts off (2c up) (2,1x,3)
- 9- 1c+3c LHA, 1W ends facing out ; 1W (1M following) casts off (3c up) (2,3,1)
- 17- 1c set, dance to top NHJ, cast off to 2pl (3c down on 21-22)
- 25- 2c+1c R&L

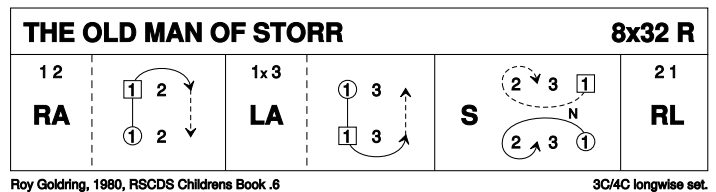

3 CULLA BAY S32 · 4S

Ann Dix: *RSCDS XLI 2* · Crib: *E-cribs* · Diagram: *Keith Rose's Diagrams*

- 1- 1c+3c turn RH ½ with person opposite, face that person | twirl R and into opposite place ; 2c+4c repeat this and face in **while**(4) 1c+3c (W leading) chase ¼ clw | curve into centre and swivel R to face out (1c facing 4pl and 3c facing 2pl)
- 9- Parallel Reels4 across
- 17- 2c+1c & 3c+4c circle4 L ; face other couple and set | ½ RHA, flowing into
- 25- 2c+4c LHA in the middle ; dance out passing same sex standing dancer on the side Rsh, and chase R (M leading) to 1pl/3pl (to 2,3,4,1).

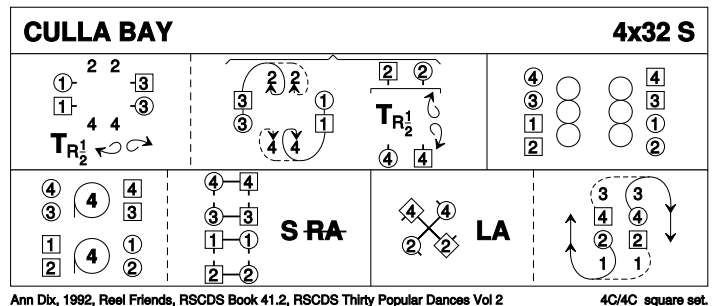

4 THE WEE COOPER O' FIFE J40 · 2/4L

Hugh Foss: Dances To Song Tunes · Crib: E-cribs · Diagram: SCDDDB Contributed Cribs & Diagrams

- 1-10 1c set, cross RH, set, lead down, cross and cast up (1,2)
 11-20 1c+2c R&L (no polite turn), cross RH (1x,2x)
 21-30 1c+2c set | ½ RHA ; set | ½ LHA | 1W+2M continue ½ LH turn **while(2)** 1M+2W (the leading M and W) cast R and out on opposite side, all finish in line across facing P
 31-40 Reel4 across the set | Pass P Rsh and dance to own side (2,1)

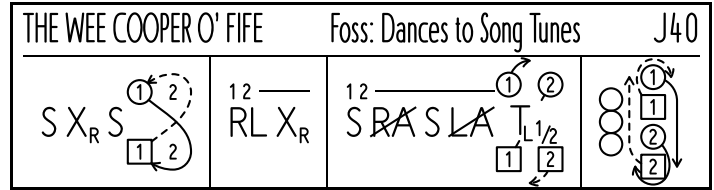

5 SANDS OF MORAR S32 · 3/4L

Barry Priddey: RSCDS XLV 6 · Crib: E-cribs · Diagram: Keith Rose's Diagrams

- 1- 1c Fig8 round 2c, giving hands
 9- All Mirror Reels3 on own side, 1c starts in, join hands on meeting P
 17- 1c turn BH | 1c dance to 3pl NHJ **while(4)** 2c+3c continue reel to top and follow behind 1c ; 3c+2c+1c set facing down | 1c cast to top, 2c+3c following to finish (1,2,3)
 25- 1c+2c Tourbillon (1c+2c turn P BH ½, opening out to one place clw in the square (1c to W side, 2c to M side) | 1c set to 2c ; repeat figure (to 2x,1x) | 2c+1c cross RH) (2,1,3)

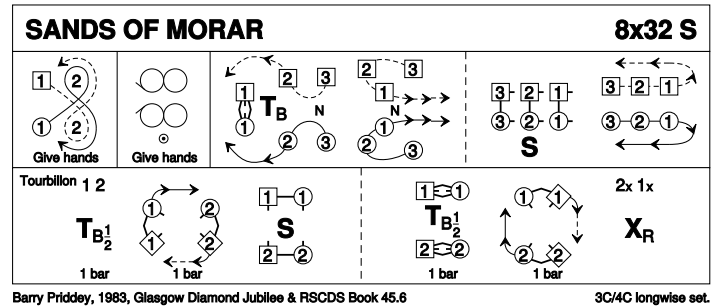

6 INCHMICKERY J32 · 5/5L

Roy Goldring: RSCDS LIII 23 · Crib: E-cribs · Diagram: Keith Rose's Diagrams

- 1- 1c+2c circle4 L ; 1c long cast to 3pl (2c+3c up) (2,3,1,4,5)
 9- Teapots R ; and L (1c RHA with C on R ; LHA with C on L)
 17- 1M+5W & 1W+2M Turn RH to places ; 1M+2W & 1W+5M repeat LH
 25- 1c long cast to 5pl (4c+5c up) ; 5c+1c circle4 R (2,3,4,5,1)

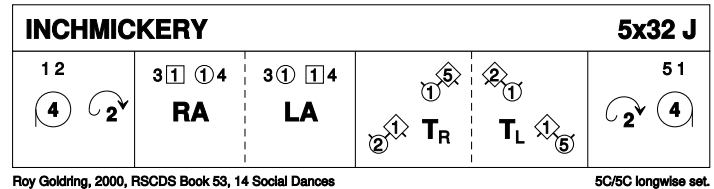

7 FLOWERS OF EDINBURGH R32 · 3/4L

RSCDS I 6 · Crib: E-cribs · Diagram: SCDDDB Contributed Cribs & Diagrams

- 1- 1W followed by 1M casts off 2, 1W crosses below 3c and casts up M side **while** 1M dances up the middle, both to P's place {6} | 1c set
 9- 1c repeat with 1M casting, finishing in original places
 17- 1c lead down the middle and up
 25- 1c+2c Pousette

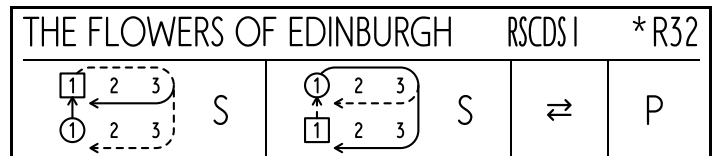

Intervall

8 SCOTT MEIKLE R32 · 4/4L

Alice McLean: RSCDS XLVI 3 · Crib: E-cribs · Diagram: Keith Rose's Diagrams

- 1- 1c cross RH | cast (2c up) ; ½ Fig8 up (2,1,3,4)
- 9- 1c+3c RHA, LHA (2,1,3,4)
- 17- Lsh opposing Reels3 across: (1W+3W behind dancing as one) with 2c and (3M+1M behind) with 4c (to 2,3,1,4)
- 25- 1c+4c ½ R&L ; turn RH 1½ (2,3,4,1)

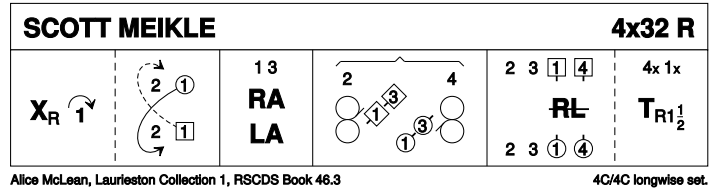

9 THE TRIPITUP TROUPE J32 · 3/4L

Gary Coull: Jubilee Book 1929-2004 [Banffshire] · Crib: E-cribs · Diagram: Keith Rose's Diagrams

- 1- 1c cross down (2c up) | set as in DTr ; 1c cast R round 1cnr to face 1cnr on diagonal
- 9- Reel4 with 1cnrs, at end 1c make fast LH turn to face 2cnr
- 17- Reel4 with 2cnrs, finish (2,1,3).
- 25- All Circle L {3}, put R foot ahead and swivel L ; all chase cclw. to places in Skip-change. (2,1,3)

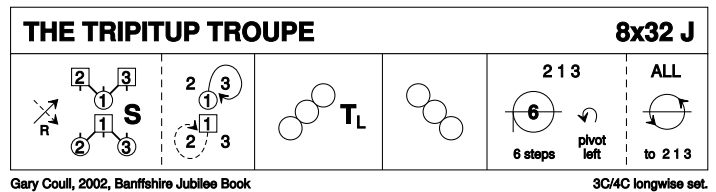

10 CATE'S CONUNDRUM S32 · 3/3L

Alex Gray: Tweeddale Collection, Volume 4 · Crib: E-cribs · Diagram: Keith Rose's Diagrams

- 1- 1c+2c Pousette (1,2,3)
- 9- 1c+2c ½ RHA | Set diagonally ; twirl to sideline (2x,1x,3) | 1c turn RH to face 1cnr as 2c cross RH
- 17- 1c+1cns "corners pass and turn" with the change "corners turn ½ RH and twirl to opposite corner" ; 1c+2cnrs repeat, to (3x,1,2x), 1c face out
- 25- Reels3{6} on the sides, 1c Rsh to 3cnr (pos) | 2c+3c cross RH (3,1,2)

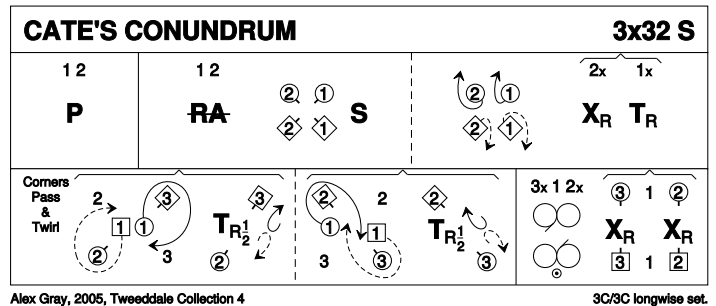

11 SWISS LASSIE R32 · 3/4L

Rosi Betsche: RSCDS XXXIX 1 · Crib: E-cribs · Diagram: SCDDDB Contributed Cribs & Diagrams

- 1- 1c cast off 2 (dance in to begin) (2c+3c up) ; 2c+1c 1¼ turn RH to midline, facing P
- 9- 2c+1c Reel4 on midline, 2M and 1W end facing opposite side, with P behind
- 17- 2c & 1c chase clw round 3c to (1,3,2) ; All A&R
- 25- 3c+2c turn RH ½, leading into ½ RHA, to sidelines ; 1c+2c repeat (2,1,3)

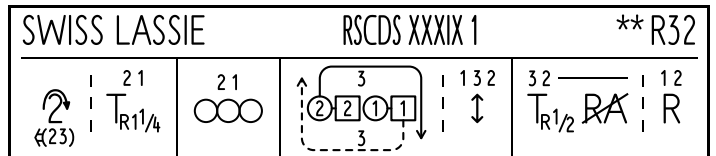

12 GOTHENBURG'S WELCOME J32 · 3/4L

Bobby Munro: RSCDS XXXVII 3 · Crib: E-cribs · Diagram: Keith Rose's Diagrams

- 1-4 1c cast off one place (2c up) | 1c set advancing to face 1cnrs
- 5-16 Dance to each corner and set ("Free" cnrs set diagonally while {2} centre dancers change place Rsh with the facing cnr, who in the centre pass Rsh to face next cnr on R | repeat five times, on alternating diagonals), 1c finish facing 3cnr position)
- 17- 1c ½Reel4 on 1diag, pass Rsh ; ½Reel4 on 2diag (2,1,3)
- 25- 2c+1W & 1M+3c RHA ; 2c+1c+3c turn RH.

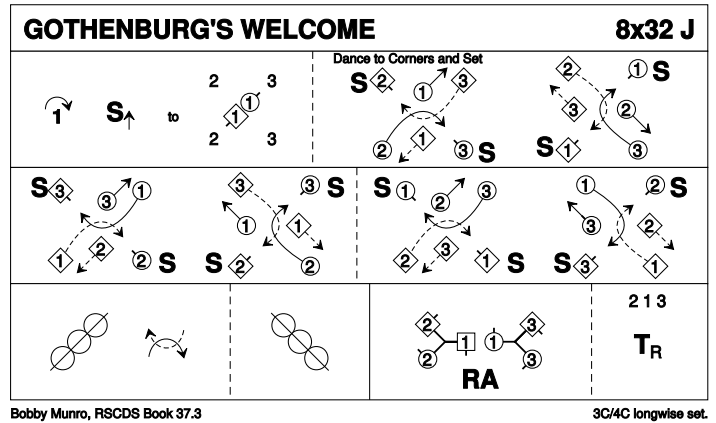

13 BRUCE FRAZER OF STRATHKINNESS S32 · 3/4L

Linda C Gaul: 75 Years of Dancing in St Andrews · Crib: E-cribs · Diagram: Keith Rose's Diagrams

- 1- 1c+2c S&Rotate (set to P | cast 1 place clw ; change place RH with P | chase 1 place clw) (2,1,3)
- 9- 1c+3c RHA ; 2c+1c LHA, finish facing 1cnr
- 17- set to and turn 1cnrs BH ; open (cnr leading) into circle 4L, finish facing 2cnr
- 25- set to and turn 2cnrs BH ; open (cnr leading) into circle 4L (2,1,3)

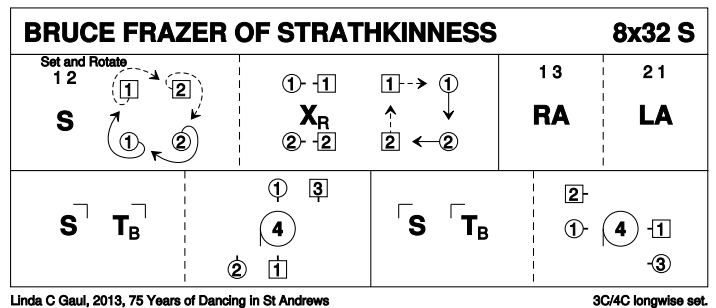

14 DUKE OF PERTH R32 · 3/4L

RSCDS I 8 · Crib: E-cribs · Diagram: Keith Rose's Diagrams

- 1- 1c turn RH, cast off (2c up) ; turn LH to face 1cnrs
- 9- Turn CPCP, to face 1cnrs
- 17- 1c set to and turn 1cnrs BH ; set to and turn 2cnrs BH
- 25- Reels3{6} on the sides (Lsh to 1cnr) | 1c cross RH to 2pl.

